

UNIT 3 – MEASUREMENT – PART 1

Assignment	Title	Work to complete	Complete
	Vocabulary	Complete the vocabulary words on the attached handout with information from the booklet or text.	
1	<i>The Metric System</i>	Part A Part B Part C	
2	<i>The Imperial System</i>	Part A Part B Part C	
3	<i>Converting Measurements Between Systems</i>	Converting Measurements Between Systems	
4	<i>Metric and Imperial Estimation</i>	<i>Metric and Imperial Estimation</i>	
5	<i>Perimeter</i>	Perimeter	
6	<i>Circumference</i>	Circumference	
7	<i>Area</i>	Area	
8	<i>Surface Area</i>	Surface Area	
9	<i>More Measurement</i>	Vernier Calipers	
10	<i>More Measurement</i>	Micrometers	
Mental Math	Mental Math Non-calculator practice	Get this page from your teacher	
Practice Test	Practice Test How are you doing?	Get this page from your teacher	
Self-Assessment	Self-Assessment <i>“Traffic Lights”</i>	On the next page, complete the self-assessment assignment.	
Chapter Test	Chapter Test Show me your stuff!		

Traffic Lights

In the following chart, decide how confident you feel about each statement by sticking a red, yellow, or green dot in the box. Then discuss this with your teacher **BEFORE** you write the test.

Statement	Dot
After completing this chapter;	
• I understand the relationship between units in the SI and imperial systems	
• I can convert a measurement from SI units to imperial units	
• I can convert a measurement from imperial units to SI units	
• I can estimate measurements using a referent in both SI and imperial systems	
• I can calculate perimeter, circumference, and area in metric and imperial units	
• I can calculate the surface area of a three-dimensional object in metric and imperial units	
• I can read measurements from a vernier caliper and a micrometer	

Vocabulary: Chapter 3

MEASUREMENT – PART 1

<p>budget</p> <p>*this term has been completed for you as an example</p>	<p><u>Definition</u></p> <p>an estimate of the amount of money to be spent on a specific project or over a given time frame</p>	<p><u>Diagram/Example:</u> A sample of a personal monthly budget:</p> <table border="1" style="width: 100%; border-collapse: collapse;"> <thead> <tr> <th colspan="2" style="text-align: left;"><u>Net Pay</u></th> <th colspan="2" style="text-align: right;"><u>\$2500</u></th> </tr> </thead> <tbody> <tr> <td>Rent</td> <td style="text-align: right;">\$600</td> <td>Recreation</td> <td style="text-align: right;">\$100</td> </tr> <tr> <td>Telephone</td> <td style="text-align: right;">\$75</td> <td>Personal Care</td> <td style="text-align: right;">\$100</td> </tr> <tr> <td>Utilities</td> <td style="text-align: right;">\$75</td> <td>Savings</td> <td style="text-align: right;">\$150</td> </tr> <tr> <td>Food</td> <td style="text-align: right;">\$500</td> <td>Spending (CDs...)</td> <td style="text-align: right;">\$200</td> </tr> <tr> <td>Transportation</td> <td style="text-align: right;">\$500</td> <td>Other expenses</td> <td style="text-align: right;">\$100</td> </tr> <tr> <td>Clothing</td> <td style="text-align: right;">\$100</td> <td></td> <td></td> </tr> <tr> <td>Total</td> <td></td> <td></td> <td style="text-align: right;">\$2,500</td> </tr> </tbody> </table>	<u>Net Pay</u>		<u>\$2500</u>		Rent	\$600	Recreation	\$100	Telephone	\$75	Personal Care	\$100	Utilities	\$75	Savings	\$150	Food	\$500	Spending (CDs...)	\$200	Transportation	\$500	Other expenses	\$100	Clothing	\$100			Total			\$2,500
<u>Net Pay</u>		<u>\$2500</u>																																
Rent	\$600	Recreation	\$100																															
Telephone	\$75	Personal Care	\$100																															
Utilities	\$75	Savings	\$150																															
Food	\$500	Spending (CDs...)	\$200																															
Transportation	\$500	Other expenses	\$100																															
Clothing	\$100																																	
Total			\$2,500																															
<p>base unit</p>	<p><u>Definition</u></p>	<p><u>Diagram/Example</u></p>																																
<p>foot (ft or ')</p>	<p><u>Definition</u></p>	<p><u>Diagram/Example</u></p>																																
<p>imperial system</p>	<p><u>Definition</u></p>	<p><u>Diagram/Example</u></p>																																

inch (in or ")	<u>Definition</u>	<u>Diagram/Example</u>
micrometer	<u>Definition</u>	<u>Diagram/Example</u>
mile (mi)	<u>Definition</u>	<u>Diagram/Example</u>
referent	<u>Definition</u>	<u>Diagram/Example</u>
surface area	<u>Definition</u>	<u>Diagram/Example</u>

Systeme international d'unités (SI)	<u>Definition</u>	<u>Diagram/Example</u>
Vernier caliper	<u>Definition</u>	<u>Diagram/Example</u>
yard (yd)	<u>Definition</u>	<u>Diagram/Example</u>

THE METRIC SYSTEM

The **Metric System** is a system of measurement based on multiples of 10, where the base unit for length is the metre. Since the 1960s, the International System of Units (SI) ("**Système International d'Unités**" in French, hence "SI") has been the internationally recognized standard metric system. Metric units are widely used around the world. To convert from one unit to another in the metric system, we multiply or divide by powers of 10 and attach a different prefix to the base unit (metre). The standard set of prefixes used in the metric system and their meanings is found below.

PREFIX	SYMBOL	QUANTITY		
tera	T	trillion	1 000 000 000 000	1 000 000 000 000
giga	G	billion	1 000 000 000	1 000 000 000
mega	mg	million	1 000 000	1 000 000
kilo	k	thousand	1000	1 000
hecto	h	hundred	100	100
deca	da	ten	10	10
basic unit		one	1	1
deci	d	one-tenth	0.1	1/10
centi	c	one-hundredth	0.01	1/100
milli	m	one-thousandth	0.001	1/1000
micro	μ	one-millionth	0.000 001	1/ 1 000 000
nano	n	one-billionth	0.000 000 001	1/ 1 000 000 000
pico	p	one-trillionth	0.000 000 000 001	1/1 000 000 000 000

There are a lot of prefixes in the table above that we do not use on a daily basis, but no doubt you will have heard of many of these. My computer's hard drive is measured in GB – gigabytes. And a common measurement in science is a nanometere – it is very small!

There are some prefixes that you need to know, and the relationship between them. These are the prefixes from kilometre to millimetre – km to mm. They are km, hm, dam, m, dm, cm, mm. There is a little rhyme that might help you remember the order of these units: **King Henry died, Mary didn't cry much**. Each first letter in this phrase, **KHDMDCM**, represents the first letter in the corresponding unit, in order from km down to mm. The only area left for confusion is between decametres and decimeters. I remember these two because "a" comes before "i" in the alphabet and so decametres comes first in the little rhyme.

When you know the prefixes in order, it is easy to use them. Make a set of stairs and label the top step "km" and the bottom step "mm" and then fill in the rest using the rhyme like this:

Notice that I have also put two arrows beside the staircase. These are used for converting between the units on the staircase.

If you are going **UP** the stairs, you will multiply by 10 for each step – now you put a “x” sign on the left of the “10” going up.

If you are going **DOWN** the stairs, you will divide by 10 for each step – now you put a “÷” sign to the left of the “10” going down.

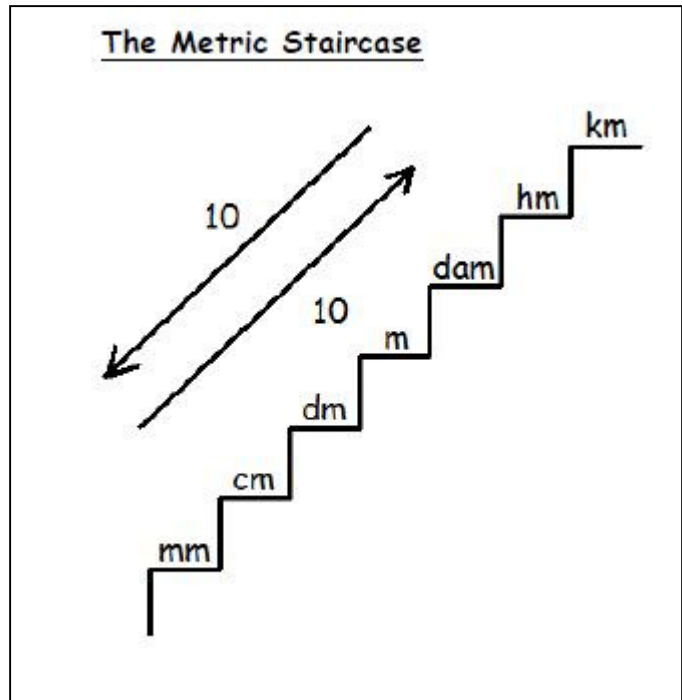

YOU NEED TO LEARN THIS STAIRCASE so you can use it as the order of the prefixes will NOT be given to you on the test or exam.

Another way to convert between these common metric units, either multiply or divide by 10 **for each** arrow as shown below.

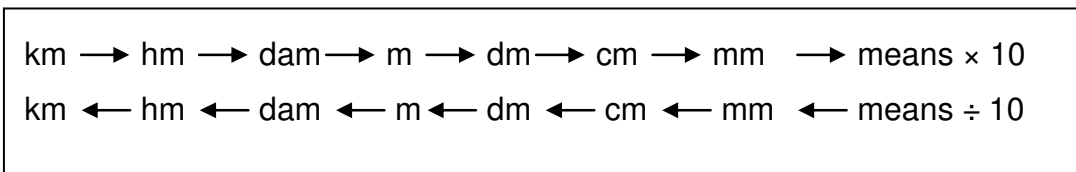

Referents – objects that represent approximately one unit of measurement - for these units include: the thickness of a paperclip for mm, the width of an adult baby finger for a cm, and the length of a pace (2 steps) for a metre.

As with every system of measurement, different base units are used for different types of measurement. The following chart shows the different base units in the metric system.

MEASUREMENT	UNIT	SYMBOL
length	metre	m
mass	gram	g
capacity	litre	L
temperature	degrees Celsius	⁰ C

ASSIGNMENT 1 – THE METRIC SYSTEM

Part A Choose the most sensible measure. Circle your answer.

1. Length of a small paper clip.
31 mm 31 cm 31 m 31 km
2. Length of a tennis racket.
68 mm 68 cm 68 m 68 km
3. Distance around a racetrack.
2 mm 2 cm 2 m 2 km
4. Length of a canoe
4 mm 4 cm 4 m 4 km
5. Length of a key.
54 mm 54 cm 54 m 54 km
6. Height of a woman.
160 mm 160 cm 160 m 160 km
7. Width of a room.
8 mm 8 cm 8 m 8 km
8. Distance from Vancouver to Hope.
125 mm 125 cm 125 m 125 km
9. Length of a bowling alley.
18 mm 18 cm 18 m 18 km
10. Height of a giant redwood tree.
67 mm 67 cm 67 m 67 km
11. Length of a safety pin.
26 mm 26 cm 26 m 26 km
12. Width of a desk.
75 mm 75 cm 75 m 75 km
13. Long-distance run.
10 000 cm 10 000 m 10 000 km

Part B Convert the following measurements as indicated.

- 1) 38 km = _____ m
 - 2) 0.4 km = _____ cm
 - 3) 758 mm = _____ m
 - 4) 0.527 km = _____ mm
 - 5) 8.5 m = _____ mm
 - 6) 2460 mm = _____ cm
 - 7) 155 cm = _____ m
 - 8) 1.6 m = _____ km
 - 9) 1245 m = _____ km
 - 10) 247 cm = _____ mm
 - 11) 16.5 m = _____ cm
 - 12) 2500 mm = _____ km
- Note: These units above are the common units used. Students are also responsible for knowing the less common units as illustrated in the following conversions.
- 13) 30 dam = _____ m
 - 14) 67 dm = _____ cm
 - 15) 456 m = _____ dam
 - 16) 920 mm = _____ dm
 - 17) 7800 hm = _____ km
 - 18) 11 km = _____ dm

Part C

1) The diameter of a loonie is about 26.5 mm. What is this measurement in centimetres?



2) A tree house is 1.2 m high. If each step is 20 cm high, will seven steps reach the tree house?

3) Nora needs 35 tiles for a floor. She finds a stack of tiles that is 0.5 m high. If each tile is 1.2 cm thick, are there enough tiles in the stack for her project?

4) William wants to put Christmas lights along the peak and edges of his roof.

a) How many metres of lights will he need?

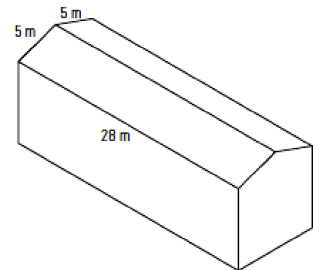

b) Express this length in cm.

THE IMPERIAL SYSTEM

The Imperial System of measurement or **Imperial units** is a set of units, with the foot being the base unit. The units were introduced in the United Kingdom and the Commonwealth countries, but most of these countries now use the metric system. The exception is the United States. For measurements of length, the imperial system uses inches, feet, yards, and miles. It is important to be familiar with imperial measurements because they are still used in many areas like construction, and because the United States is so close to Canada.

Referents for these units include: inch - the width of an adult thumb, foot – the length of an adult foot, yard – the length from the nose to the end of the outstretched fingertip

The relationship between the units in the imperial system is not as friendly as the metric system. To convert between units requires knowledge of the divisions as shown below.

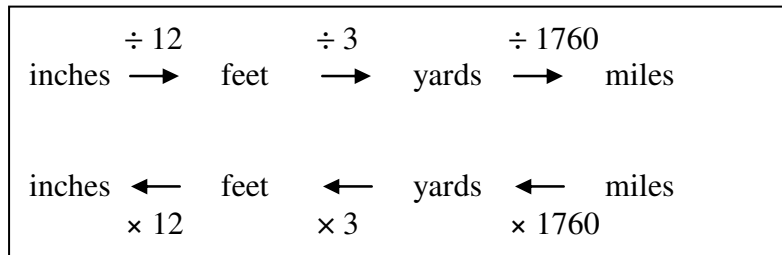

1 mile = 1760 yd
 1 mile = 5280 ft
 1 yd = 3 ft = 36 in
 1 ft = 12 in

The standard units used in the metric system (for length) are shown below.

UNIT	SYMBOL
inch	" or in.
foot	' or ft.
yard	yd.
mile	mi.

This imperial ruler shows inches which are divided into 16th. Often, rulers show the first inch divided into 32nd of an inch. Each inch on the ruler is marked with a long line and is labeled 1, 2, 3, 4, and so on. In between each inch marker is another long line which marks each half inch. In between each of these divisions is a slightly longer line which marks each quarter (1/4) of an inch.

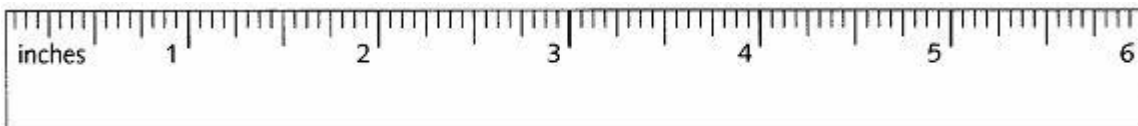

ASSIGNMENT 2 – IMPERIAL SYSTEM

Part A

To measure a length using an imperial ruler, count the whole number of inches, and then count the number of 16th of the next inch until the mark is reached. For example, letter H below is pointing at a measurement of 5 — in.

1. State the length (to the closest $\frac{1}{16}$ th of an inch) for the points A to G on the ruler below.

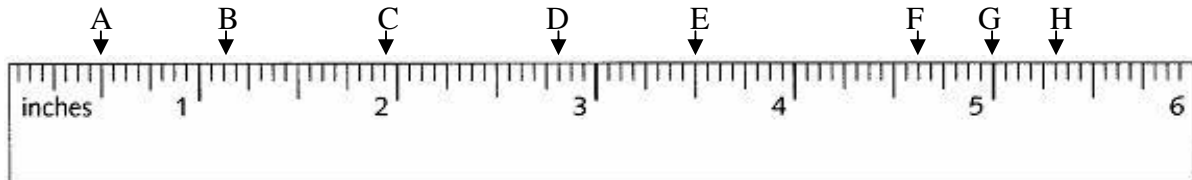

2. Find the length of the objects below to the closest $\frac{1}{16}$ th of an inch.

a)

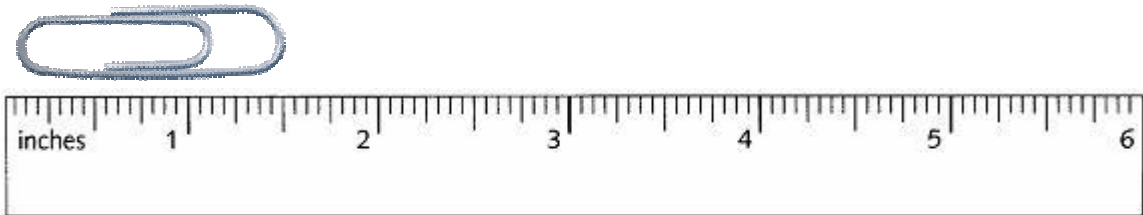

b)

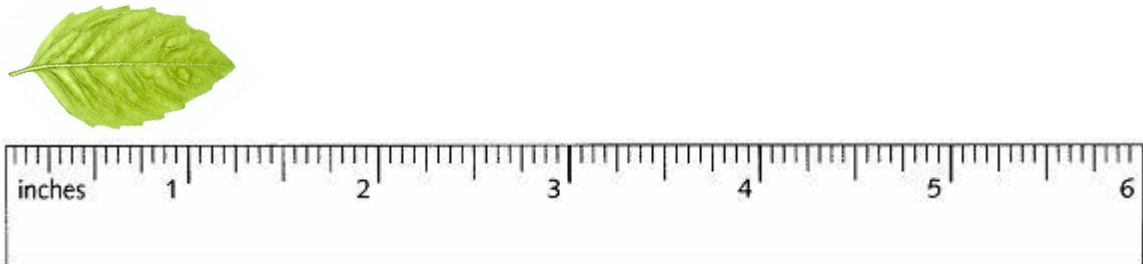

c)

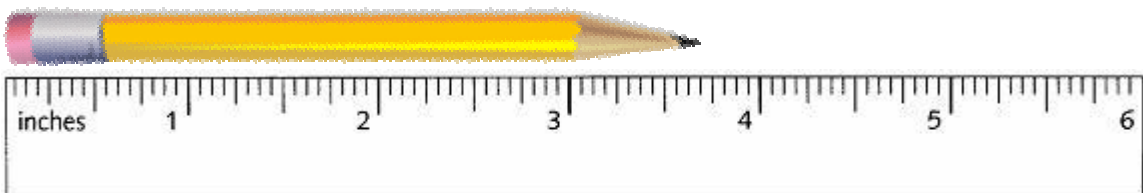

d)

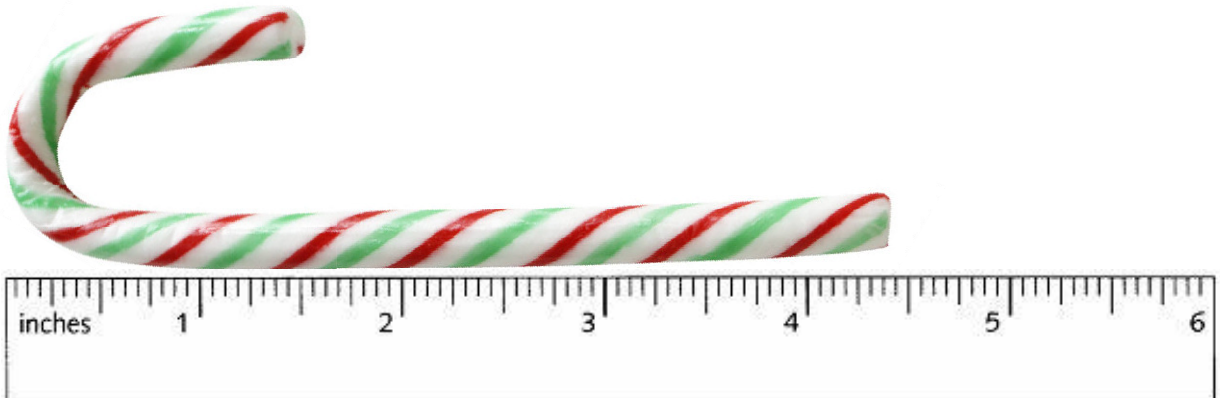

2) Convert the following measurements.

a) $38 \text{ ft} = \underline{\hspace{2cm}}$ in

b) $0.4 \text{ mi} = \underline{\hspace{2cm}}$ yd

c) $7.5 \text{ mi} = \underline{\hspace{2cm}}$ ft

d) $72 \text{ in} = \underline{\hspace{2cm}}$ ft

3) Ray is building a fence around his yard using pre-made panels that are sold in 8 ft lengths. The perimeter of the yard is 32 yd. How many fence panels should he buy?

Often Imperial Units are used in combination.

For example, Jan might say she is 5 ft 10 in tall. These types of measurements can also be converted within the Imperial System.

Jan is 5' 10" tall. How tall is Jan in inches?

1 ft = 12 in., so in 5 ft there are

$$5 \text{ ft} \times 12 \text{ in.} = 60 \text{ in.}$$

Jan's height in inches is:

$$60 \text{ in.} + 10 \text{ in.} = 70 \text{ in.}$$

Part B

4) Convert the following measurements.

a) $7 \text{ yd } 2 \text{ ft} = \underline{\hspace{2cm}}$ ft

b) $3 \text{ yd } 1 \text{ ft} = \underline{\hspace{2cm}}$ in

c) $5 \text{ mi } 12 \text{ yd} = \underline{\hspace{2cm}}$ ft

d) $5 \text{ mi } 16 \text{ yd } 2 \text{ ft} = \underline{\hspace{2cm}}$ in

e) $3 \text{ mi } 9 \text{ yd } 2 \text{ ft} = \underline{\hspace{2cm}}$ ft

- 5) The Olympic Marathon is a running race that is 26 miles 385 yards long. If Sebastian's stride is about 1 yard long, how many strides will he take in a marathon run?
- 6) If each board in a fence is 6 inches wide, how many boards will Josée need to fence all 4 sides of a playground that is 60 ft wide by 125 feet long?
- 7) Riley bought 50 ft of rope. He cut off pieces that total 34' 8" do far. How much rope does he have left?
- 8) A circular garden is 7'4" in diameter. A geranium is planted every foot along the outside of the garden (circumference). How many geraniums are needed?

- 9) A pet store has 10 cages for sale. They are 5 cages that are 2'8" wide, 3 cages that are 4'6" wide, and 2 cages that are 1'8" wide. Can these cages fit side by side along a wall that is 30' long?

Imperial Units are also stated in fraction form.

For example, 7 $\frac{1}{4}$ inches. These types of measurement can be converted to feet and inches.

A staircase has eight steps that are 7 $\frac{1}{4}$ inches high. What is this height in feet and inches?

Consider the whole numbers first:

$$7 \text{ inches} \times 8 = 56 \text{ inches}$$

Consider the fraction next:

$$\frac{1}{4} \text{ inches} \times 8 = 2 \text{ inches}$$

What is the total height?

$$56 \text{ inches} + 2 \text{ inches} = 58 \text{ inches}$$

What is this height in feet and inches?

$$58 \text{ inches} \div 12 = 4 \text{ whole feet with a remainder } 10 \text{ inches}$$

So, the height of the staircase is 4 feet 10 inches

Part C

9) Convert the following measurements.

a) $\frac{3}{4}$ mi = _____ yd

b) $2 \frac{3}{4}$ mi = _____ ft

c) $\frac{1}{4}$ ft = _____ in

d) $6 \frac{1}{4}$ yd = _____ ft

CONVERTING MEASUREMENTS BETWEEN SYSTEMS

It is important to be able to convert metric units to imperial units, and vice versa. Below are some of the common conversions available for units of length. Note that the sign “ \approx ” means approximately. These conversions are not exact but are what will be used for this course. Online conversions calculators give more precise conversions if needed.

1 inch \approx 2.54 centimetres
1 foot \approx 30.5 centimetres
1 foot \approx 0.305 metres
1 yard \approx 0.915 metres
1 mile \approx 1.6 kilometres

Use these conversion factors by multiplying when converting from left to right or by dividing when converting from right to left.

Example 1: 24 ft = _____ m

The conversion from ft to m is 0.305. This is a left to right conversion so multiply.

$$\text{So, } 24 \text{ ft} \times 0.305 = 7.32 \text{ m}$$

Example 2: Andrea’s height is 5’8”. What is her height in centimetres?

First convert Andrea’s height all to inches.

$$5' \times 12 = 60'' + 8'' = 68''$$

Then change the inches to centimetres by using the conversion factor. This can be done by multiplying or by setting up a proportion and solving.

$$68'' \times 2.54 = 173 \text{ cm}$$

$$\frac{\text{cm}}{\text{in.}} \quad \frac{2.54}{1} = \frac{x}{68}$$

$$x = 2.54 \times 68 \div 1 = 173 \text{ cm}$$

ASSIGNMENT 3 – CONVERTING MEASUREMENTS BETWEEN SYSTEMS

1) Convert the following measurements.

a) 8 in = _____ cm

f) 145 m = _____ in

b) 9.5 mi = _____ km

g) 1.5 m = _____ ft

c) 25 yd = _____ m

h) 123 km = _____ mi

d) 67 ft = _____ m

i) 27 cm = _____ in

e) 24 ft = _____ cm

j) 55 cm = _____ ft

2) Mount Logan is Canada's highest mountain. It measures 19 551 ft. What is that height in metres?

3) The Capilano Suspension Bridge in North Vancouver is 173 m across and 70 m above the river. What are these distances in feet?

4) Jiri's boat and trailer is 20 ft 6 in. long. His garage is 6.2 m long. Will the boat and trailer fit in his garage?

5) Charlie drove from Calgary to Saskatoon. If this distance is 620 km, how far is this in miles?

6) Carla needs 3.5 m of cloth. However, the cloth she wants to buy costs \$9.79 per yard. How much will this cloth cost?

7) A nickel is 1.95 mm thick. About how long is a \$2.00 roll of nickels in inches? Round your answer to the nearest whole inch. Hint: How many nickels (5¢) are in \$2.00?

8) An airline has size limits for checked baggage. The length, width and height of all luggage must add up to no more than 157 cm. Will the airline accept a suitcase that measures 17 in. by 26 in. by 14 in.?

ASSIGNMENT 4 – METRIC AND IMPERIAL ESTIMATION

Different units are appropriate to be used when estimating or stating the size of something. For example, you wouldn't say that the desk you are sitting at is so many kilometres long, or the distance you live from school is that many millimetres. These are not appropriate units.

1. Complete the following chart. Write the appropriate **units** for each measurement.

Choose from the following: metric – mm, cm, m, km
 imperial – in., ft., mi. (yds are used in football and golf!)

Item	Metric	Imperial
Length of a Translink bus		
Length of a \$20 bill		
Height of a 1-story building		
Width of your pencil		
Size of your big screen TV		

2. Estimate the following lengths in both metric and imperial. Give both a number and the appropriate units.

Item	Metric	Imperial
Length of a your desk		
Length of a pencil		
Height of a flagpole		
Width of an eraser		
Distance from Surrey to Vancouver		

PERIMETER

The distance around any geometric shape is known as the **perimeter**. To calculate the perimeter, simply add the lengths of all the sides together. Perimeter is always in linear units: cm, in, ft, m, etc.

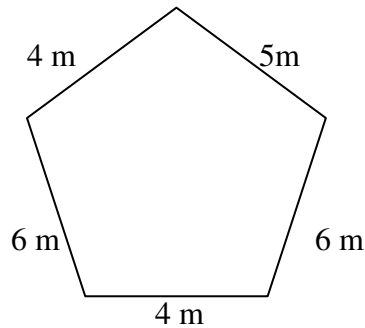

The perimeter of this figure is:

$$P = 4 + 5 + 6 + 4 + 6 = 25 \text{ m}$$

A rectangle has a special formula that can be used to calculate its perimeter. The perimeter is two of the length plus two of the width. It doesn't matter which side is called the length and which one is called the width. In math terms, this means times the length plus two times the width.

$$P = 2 \times l + 2 \times w$$

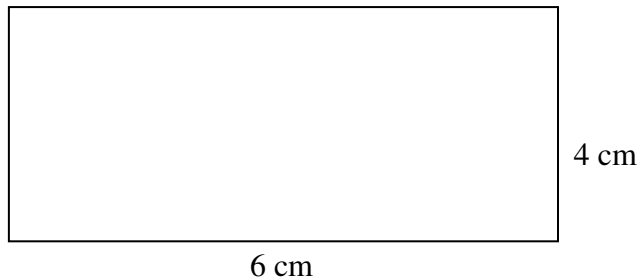

$$P = 2 \times l + 2 \times w$$

$$P = 2 \times 6 + 2 \times 4$$

$$P = 12 + 8$$

$$P = 20 \text{ cm}$$

The perimeter of **EVERY** figure is always calculated in the units given in the question. If the units in the figure are cm, the perimeter is cm; if it is in inches, the perimeter is in inches, and so on.

When solving word problems, ALWAYS draw a diagram to help you!

ASSIGNMENT 5 – PERIMETER

Calculate the perimeter of the following figures. Show your work and include the proper units in your answer.

1a)

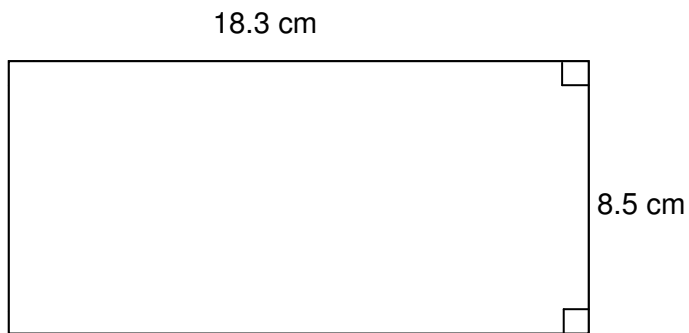

b)

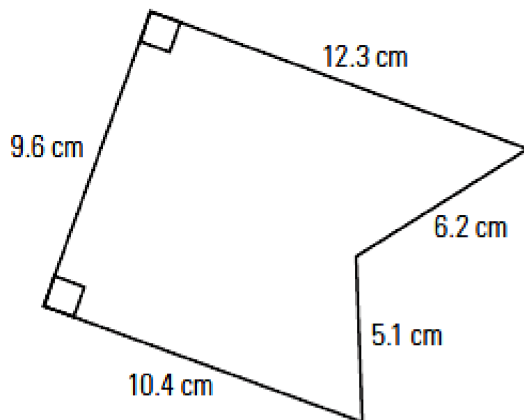

c)

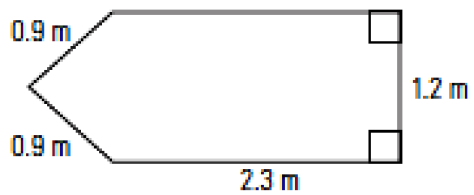

- 2) Darlene is adding lace to the edge of a tablecloth. The tablecloth is 210 cm by 180 cm. How many centimetres does she need to go all the way around the tablecloth?



- 3) Chandra is building a fence around her swimming pool to completely surround it. The pool is 25 feet long and 12 feet wide. There is a 6 ft walkway around the entire pool. How much fencing will she need?



- 4) A rectangular city pool is 40 ft wide and has a perimeter of 230 ft. What is the length of the pool?

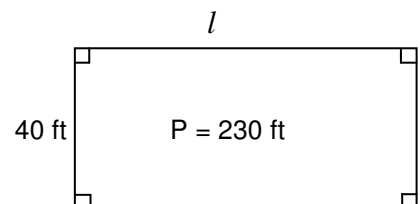

CIRCUMFERENCE

The perimeter of a circle has a special name and formula as it is impossible to “measure” a circle’s sides! The special name for perimeter of a circle is the circumference.

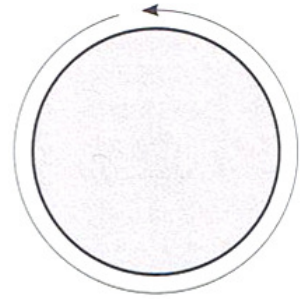

The formula for circumference of a circle is:

$$C = 2\pi r \quad \text{OR} \quad C = \pi d \quad \text{where}$$

r = radius of a circle

d = diameter of a circle

π = pi, a constant found on your calculator.

It has a value of approximately 3.14159

The diameter is twice the size of the radius, or the radius is half the size of the diameter. In this circle, the diameter $d = 14$ m so the radius = 7 m.

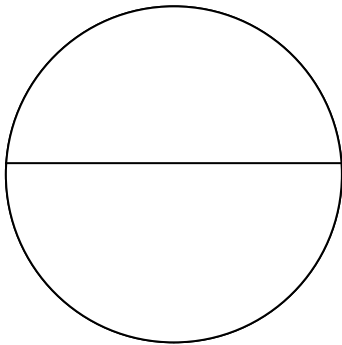

Thus the circumference calculation is:

$$C = 2\pi r$$

OR

$$C = \pi d$$

$$C = 2 \times \pi \times 7$$

$$C = \pi \times 14$$

$$C = 43.98 \text{ m}$$

$$C = 43.98 \text{ m}$$

Use the π button on your calculator. If you have difficulty finding it, please ask your teacher.

Just like straight edged shapes, the perimeter of circles is always calculated in the units given in the question. If the units in the figure are cm, the perimeter is cm; if it is in inches, the perimeter is in inches.

- 8) The sides of a flower garden are shown in the diagram below. What is the perimeter of the flower garden?

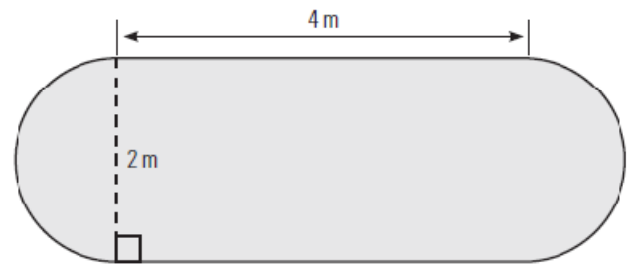

- 9) Mike sells tires. A customer told him the circumference of the wheel rim on his tires, but Mike needs the diameter to get the correct tire size. If the circumference of the customer's rim is 66 in., what is the diameter?



AREA

In geometry, area refers to the measure of a region. It is ALWAYS in square units – cm^2 , in^2 , m^2 , etc. The area of a geometric figure is the number of square units needed to cover the interior of that figure. The following formulas are used to find area. These formulas are provided for you on a sheet similar to the one at the end of this booklet for the provincial exam.

In equations, the symbol for area is a capital $a \rightarrow \mathbf{A}$.

Rectangle:

Area is the length (or base) times the width (or height). Both terms are used depending on author.

$$\mathbf{A = l \times w \quad or \quad A = b \times h}$$

Example:

$$\begin{aligned}\mathbf{A} &= \mathbf{l \times w} \\ &= 15 \times 6 \\ &= 90 \text{ m}^2\end{aligned}$$

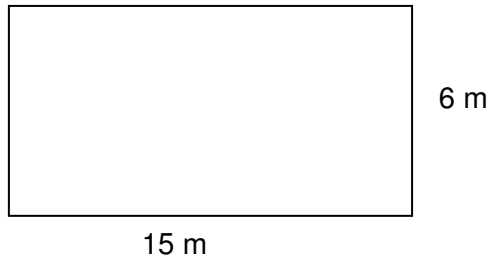

Square:

In a square, all the sides have the same length. So the area is the side times side, or side squared.

$$\mathbf{A = s \times s \quad or \quad A = s^2}$$

Example:

$$\begin{aligned}\mathbf{A} &= \mathbf{s^2} \\ &= 7 \times 7 \\ &= 49 \text{ cm}^2\end{aligned}$$

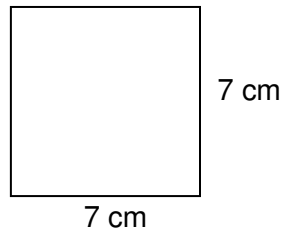

Triangle:

A triangle is any 3 sided figure. It can have any other combination of angles. The area is base times the height divided by 2. The height is always perpendicular (at right angles or 90°) to the base.

$$A = \frac{1}{2}(b \times h) \quad \text{which means} \quad A = b \times h \div 2$$

Example:

$$\begin{aligned} A &= b \times h \div 2 \\ &= 6 \times 9 \div 2 \\ &= 27 \text{ cm}^2 \end{aligned}$$

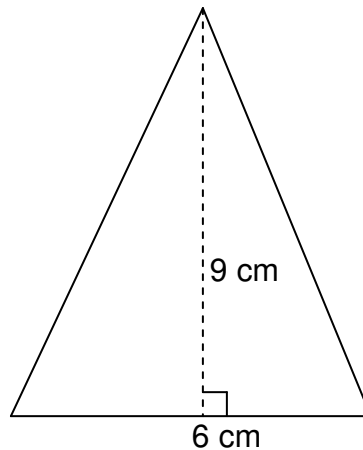

These are other shapes of triangles that still follow this formula.

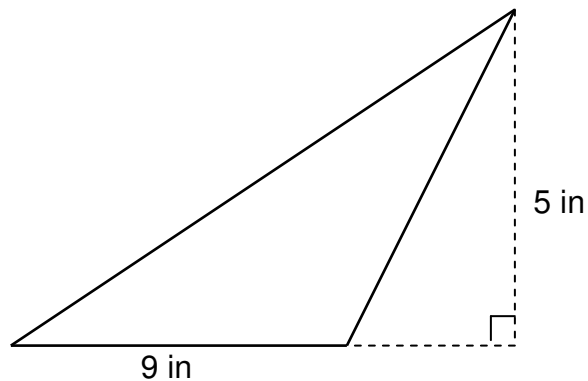
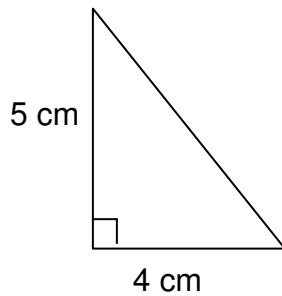

Circle:

In a circle, there are no “sides”. So the area is calculated using the length of the radius in the following formula. Remember, the radius goes from the centre of the circle to touch the circle at any place. Use the π button on your calculator.

$$\mathbf{A = \pi r^2 \quad \text{which means } A = \pi \times r \times r}$$

Example:

$$\begin{aligned} \mathbf{A} &= \mathbf{\pi r^2} \\ &= \mathbf{\pi \times 6 \times 6} \\ &= \mathbf{113.10 \text{ cm}^2} \end{aligned}$$

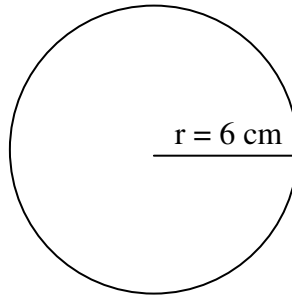

Remember, if given the diameter, divide that number by 2 before calculating the area because the radius is half the length of the diameter.

$$\begin{aligned} \mathbf{r} &= \mathbf{d \div 2} \\ &= \mathbf{18 \div 2} \\ &= \mathbf{9 \text{ in}} \end{aligned}$$

$$\begin{aligned} \mathbf{A} &= \mathbf{\pi r^2} \\ &= \mathbf{\pi \times 9 \times 9} \\ &= \mathbf{254.47 \text{ in}^2} \end{aligned}$$

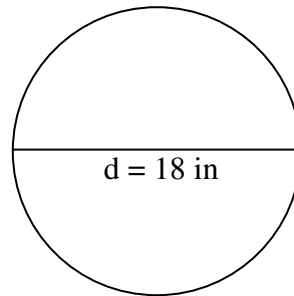

When completing area calculations between metric and imperial units, it is best to change the linear dimensions to the new unit before calculating the area.

Example:

Kuldeep must tile a floor that measures 4.4 m by 3.8 m.

a) What is the area he must cover in square inches?

First, change the dimensions of the floor into inches.

$$4.4 \text{ m} \div 0.305 = 14.43 \text{ ft} \times 12 = 173.16 \text{ in}$$

$$3.8 \text{ m} \div 0.305 = 12.46 \text{ ft} \times 12 = 149.51 \text{ in}$$

$$\text{Area}_{(\text{floor})} = 173.16 \times 149.51 = 25\,889.15 \text{ in}^2 \rightarrow 25\,889 \text{ in}^2$$

b) The tiles are 9" by 9". How many full tiles will he need?

First, find the area of the tiles.

$$\text{Area}_{(\text{tile})} = 9'' \times 9'' = 81 \text{ in}^2$$

Next, divide the area of the floor by the area of the tile.

$$25\,889 \text{ in}^2 \div 81 \text{ in}^2 = 319.62 \text{ tiles} \rightarrow 320 \text{ tiles}$$

Sometimes, area must be changed from one square unit to another. This must be done carefully!

Consider the square to the right. It has side lengths of 10 mm or 1 cm.

When finding the area of this face, we could use either measurement.

$$\begin{aligned} \text{Area} &= s \times s \\ &= 10 \text{ mm} \times 10 \text{ mm} \\ &= 100 \text{ mm}^2 \end{aligned}$$

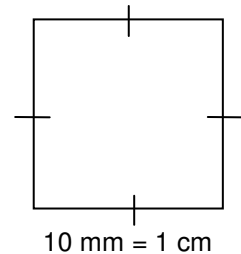

But the following is also true

$$\begin{aligned} \text{Area} &= 1 \text{ cm} \times 1 \text{ cm} \\ &= 1 \text{ cm}^2 \end{aligned}$$

Therefore, $1 \text{ cm}^2 = 100 \text{ mm}^2$

When converting between cm^2 and mm^2 , this must be observed. The following are also true based on this example.

$$\begin{aligned} 1 \text{ m}^2 &= 10\,000 \text{ cm}^2 \\ 1 \text{ km}^2 &= 1\,000\,000 \text{ m}^2 \end{aligned}$$

$$\begin{aligned} 1 \text{ yd}^2 &= 9 \text{ ft}^2 \\ 1 \text{ ft}^2 &= 144 \text{ in}^2 \end{aligned}$$

ASSIGNMENT 7 – AREA

1) Leonard is laying grass in a yard measuring 38 ft by 20 ft. What is the yard's area in square yards?

2) Suzanne needs to buy grass seed for the park. The park is 150 m by 210 m. Grass seed is sold by the square foot. How many square feet are in the park?

3) A room measures 12'8" by 10'9". Carpeting costs \$45.98/m².

a) What is the area of this room in square metres?

b) What is the cost of the carpeting for this room?

SURFACE AREA

The surface area of a three-dimensional object is the area of the entire outer surface.

There are specific formulas used to find the surface area of different geometric solids.

These formulas are in your Data Booklet as well as being explained here. Just as area is expressed in square units, surface area is also **ALWAYS** expressed in square units; – cm^2 , in^2 , m^2 , etc.

Rectangular Solid:

Surface area is calculated by finding the area of each of the three faces by multiplying length times width for the face, and then adding these areas of all 6 surfaces together.

$$\mathbf{SA = 2lw + 2lh + 2wh} \quad \text{or} \quad \mathbf{SA = 2 \times l \times w + 2 \times l \times h + 2 \times w \times h}$$

This represents the top & bottom, the front & back, and both ends.

Example:

$$\begin{aligned} \mathbf{SA} &= \mathbf{2lw + 2lh + 2wh} \\ &= 2 \times 15 \times 6 + 2 \times 15 \times 12 + 2 \times 6 \times 12 \\ &= 180 + 360 + 144 \\ &= 684 \text{ m}^2 \end{aligned}$$

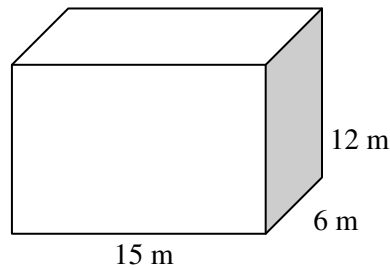

Cube:

A cube is a special rectangular solid that has all the sides have the same length. So the surface area is side times side multiplied by 6 sides.

$$\mathbf{SA = s \times s \times 6} \quad \text{or} \quad \mathbf{SA = 6s^2}$$

Example:

$$\begin{aligned} \mathbf{SA} &= \mathbf{6s^3} \\ &= 6 \times 7 \times 7 \\ &= 294 \text{ cm}^2 \end{aligned}$$

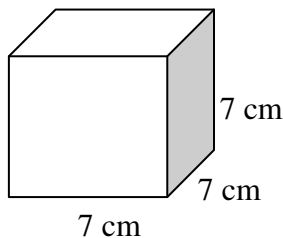

Cylinder:

The surface area of a cylinder is a two part formula found. The first part multiplies 2 times π times the radius times the height for the side of the cylinder. This represents the area of side of the cylinder (it's a rectangle). Then the top and bottom circles must be added. The area of each of these is π times the radius, times the radius or radius squared (r^2). As there are 2 circles, this must be multiplied twice.

$$\mathbf{SA = 2\pi rh + 2\pi r^2}$$

side top & bottom

Example:

$$\begin{aligned}\mathbf{SA} &= \mathbf{2\pi rh + 2\pi r^2} \\ &= \mathbf{2 \times \pi \times 3 \times 9 + 2 \times \pi \times 3 \times 3} \\ &= \mathbf{169.65 + 56.55} \\ &= \mathbf{226.2 \text{ in}^2}\end{aligned}$$

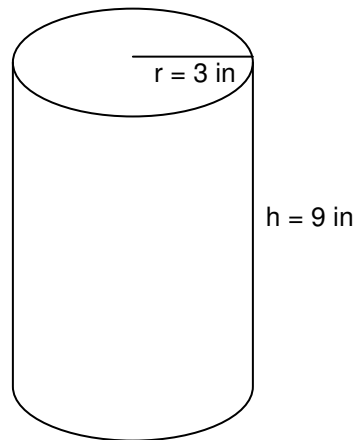

Cylinders can be tall like this can, or short and fat like the diagram below. Either way the radius is measured on the round part and the height between each circle.

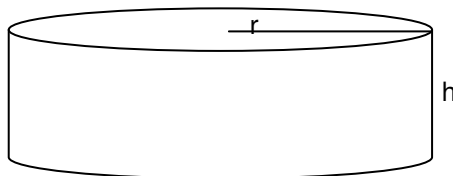

Remember, if you are given the diameter of the cylinder, divide it by 2 to get the radius.

$$\begin{aligned}r &= d \div 2 \\ r &= 14 \text{ cm} \div 2 \\ r &= 7 \text{ cm}\end{aligned}$$

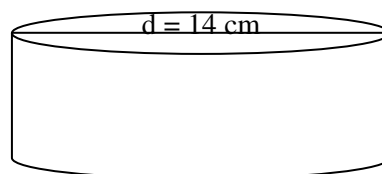

Cone:

The surface area of a cone is a two part formula found by multiplying π times the radius times the slant height plus π times radius times radius.

$$\mathbf{SA = \pi rs + \pi r^2}$$
 which means $\mathbf{A = \pi \times r \times s + \pi \times r \times r}$
side base

Example:

$$\begin{aligned}\mathbf{SA} &= \mathbf{\pi rs + \pi r^2} \\ &= \mathbf{\pi \times 6 \times 9 + \pi \times 6 \times 6} \\ &= 169.65 + 113.10 \\ &= 282.75 \text{ cm}^2\end{aligned}$$

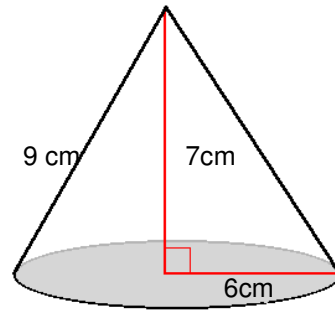

NOTE: If the base is not included, omit the circle part of the formula for the base: πr^2

Sphere:

The surface area of a sphere is found by multiplying four times π times the radius times the radius.

$$\mathbf{SA = 4\pi r^2}$$
 which means $\mathbf{SA = 4 \times \pi \times r \times r}$

Example:

$$\begin{aligned}\mathbf{SA} &= \mathbf{4\pi r^2} \\ &= \mathbf{4 \times \pi \times 5 \times 5} \\ &= \mathbf{314.16 \text{ m}^2}\end{aligned}$$

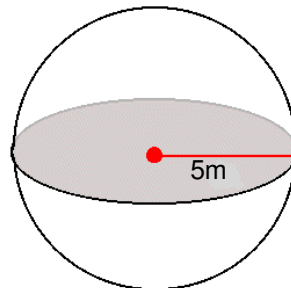

Pyramid:

The surface area of a pyramid is found by multiplying 2 times the base edge of the pyramid (b) times the slant height (s) plus the base edge of the pyramid (b) times the base edge of the pyramid (b).

$$SA = 2bs + b^2 \text{ which means } SA = 2 \times b \times s + b \times b$$

Example:

$$\begin{aligned} SA &= 2bs + b^2 \\ &= 2 \times 9 \times 12 + 9 \times 9 \\ &= 215 + 81 \\ &= 297 \text{ m}^2 \end{aligned}$$

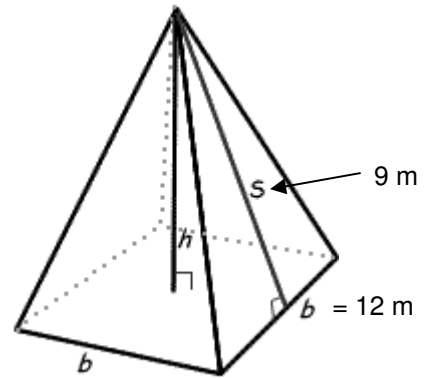

Be careful to use the slant height of the pyramid in this formula, not the height. The height goes from the vertex at the top to the middle of the base while the slant height of a face goes from the vertex at the top to the middle of the bottom of one of the sides.

ASSIGNMENT 8 – SURFACE AREA

Part A

Calculate the surface area of the figures shown below. Show all your work.

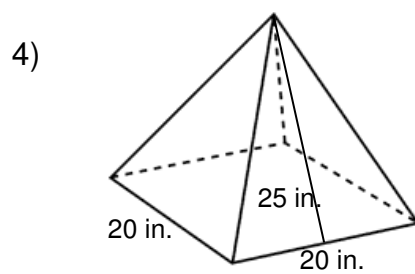
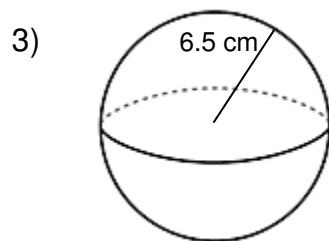
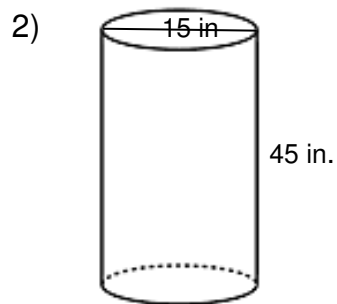
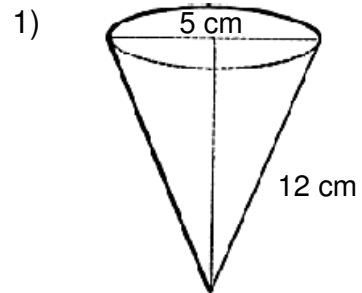

Part B

1) Jim is making a toy box. The box is 24 in. long, 18 in. deep and 36 in. tall.

a) Draw a labelled sketch to represent this toy box.

b) Calculate the surface area of the toy box in square inches.

2) Vicki is tiling her shower stall. The dimensions of the shower stall are 35" by 35" by 8 feet tall. If Vicki only needs to tile 3 sides (the 4th side is the door!), what is the surface area she will be tiling?

3) Sanjiv designs a cylindrical container to hold tennis balls. Four tennis balls will fit inside, stacked on top of each other. The tennis balls have a diameter of $3\frac{1}{4}$ inches each.

a) Draw a sketch to represent this container.

b) Calculate the surface area of the container.

4) A paper cup in the shape of a cone has a slant height of $3\frac{1}{8}$ inches and a diameter of 3 inches. How much paper is needed to make the cup?

5) Denise has a hexagonal (6-sided) fish tank. The tank is 4 feet tall and each piece of glass is $1\frac{1}{2}$ feet wide. How much glass is in the fish tank?

MORE MEASUREMENT

Rulers, metre sticks, and measuring tapes can give measurements to the nearest millimetre, or to the nearest 0.1 cm. Other measuring instruments can more accurately be measure to the nearest tenth of a millimetre, or 0.01 cm, or even to the nearest one thousandth of a millimetre or 0.001 mm depending on their scales.

The two measuring instruments you will be learning about in the booklet are the **caliper** and the **micrometer**.

PART A – VERNIER CALIPERS

A Vernier caliper is an instrument used for making accurate linear measurements. It was invented by a French engineer named Pierre Vernier in 1613. It is a common tool used ion laboratories and other industries that require precise measurements. Manufacturing of aircraft, buses, and scientific instruments are a few examples of industries in which precision measurements are essential.

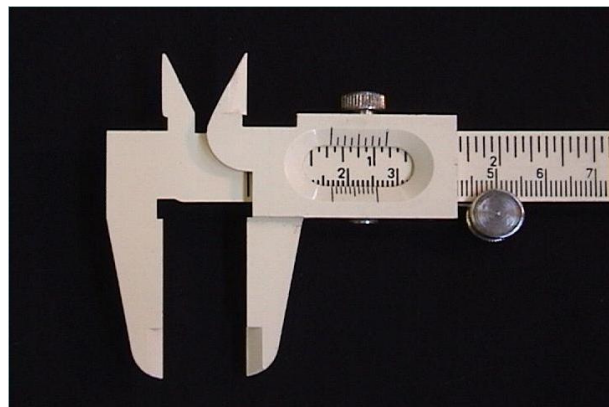

Vernier caliper

A vernier caliper (or it is often just called a “vernier” or “caliper”) is a convenient tool to use when measuring the length of a small object, or the outer or inner diameter of a round object like a pipe or hole. A vernier caliper can measure accurately to 0.01 cm, or 0.1 mm.

Reading a vernier caliper is not difficult. Once the jaws of the vernier are in place, the scales are set and the reading can be made.

There are two scales used for measuring with calipers: SI (metric) and imperial scales. These two scales can sometimes be found on the same caliper, one on the top and one on the bottom. When using each scale, the procedure for determining each measurement is slightly different. Only SI calipers will be discussed here.

Reading SI or Metric Callipers

When measuring with a metric caliper, the final measurement will usually be in centimetres (cm). There are 3 steps needed to read these vernier calipers. Each step is done independently and then the values are all added together.

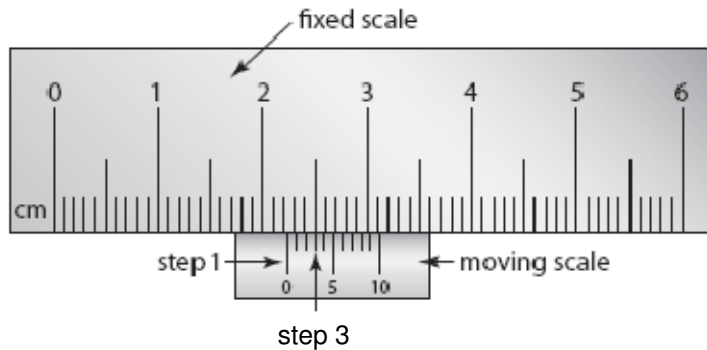

In this example, the moveable scale is on the bottom of the fixed scale. (It can also be on the top.) The numbers at the top of the fixed scale are in centimetres. Notice that there are tick marks on the fixed scale between the numbers. These are in millimetres or tenths of a centimetre. Therefore, there are 10 ticks between the numbers. There are also 10 tick marks on the moveable scale.

Step 1: Locate the “0” on the moveable or sliding scale. Now you need to determine where the “0” in this example, the zero is between 2 and 3 cm so we know our reading will be at least 2 cm. This is our first part of the reading and can be recorded as follows:

2. ____ ____ cm. Our goal is to fill in the two blanks to finish the reading.

Step 2: Now you must determine the next blank which represents the tenths of a centimetre. To do this, look carefully at the tick marks between 2 and 3 centimetres on the fixed scale. You can see that the zero line has gone past the second tick but has not yet reached the third tick. So we write down a “2” for the next blank. So our reading now looks like this:

2.2 ____ cm

Step 3: You will use the ticks on the moving scale for the final reading. Notice that one of the ticks on the moving scale lines up or matches best with a tick mark directly above it on the fixed scale. In this example, the arrow shows that the third tick matches up most closely with the line on the fixed scale. Thus, the value for the third blank must be a 3, and our reading would be:

2.23 cm

Note: it doesn't matter which line is matched on the fixed scale as we read from the moveable scale.

This may sound complicated but it really is not once you try a few. Now you are required to watch a video at the following web address. It will show you exactly what was just explained and last about a minute and a half. Be patient, it will take a minute or so to load, and don't worry about all her big words – just watch *what* is happening. If you have problems, talk to your teacher who has it saved on their computer.

<http://phoenix.phys.clemson.edu/labs/cupol/vernier/vernier8.mpg>

Other sites that will help you if you are having any trouble are the following:

<http://www.physics.smu.edu/~scalise/apparatus/caliper/>

<http://www.upscale.utoronto.ca/PVB/Harrison/Vernier/Vernier.html>

This site has a simulation that allows you to move the sliding scale and then practice reading the caliper.

<http://www.physics.smu.edu/~scalise/apparatus/caliper/tutorial/>

<http://www.members.shaw.ca/ron.blond/Vern.APPLET/>

ASSIGNMENT 9 – VERNIER CALIPERS

Write their measurements down underneath each caliper.

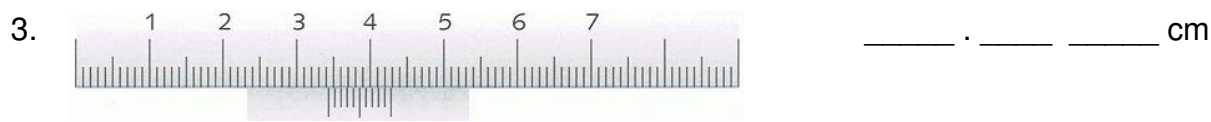

PART B – MICROMETERS

Micrometers are another tool that can be used for making small, precise lengths. In fact, micrometers can make even smaller and more precise measurements than a vernier caliper can! Micrometers often measure things like the thickness of the walls of a pipe, nuts and bolts, washers, and nails. While vernier calipers can measure accurately to the nearest tenth of a millimetre (0.1 mm), a micrometer can measure to the nearest hundredth of a millimetre (0.01 mm).

The micrometer on the top right shows the standard design of a micrometer. The areas that we will concentrate on are the sleeve or barrel and the thimble. The thimble is the moving scale on a micrometer.



Imperial micrometer

As the jaws open and the space between the anvil and the spindle gets larger, the thimble turns and goes further down the barrel. This top micrometer is calibrated in imperial units whereas the second photo shows an SI or metric micrometer. All the parts are the same, just the scales are different.



Metric micrometer



Metric micrometer's barrel and thimble

This last photo shows an enlargement of the barrel and thimble of the SI or metric micrometer. This is the type of photo or diagram that you will be reading the measurements from.

Reading SI or Metric Micrometers

When an object is placed in the jaws of a micrometer between the anvil and the spindle, the thimble is turned in order to make the object, like a pencil, fit. As the thimble is turned it moves to the right (in the diagram below) and the length on the barrel increases.

To read any length, first look at the top of the barrel reading. This scale is in millimetres. Simply count from the zero to where the thimble cuts across the barrel. In this example, the thimble crosses the barrel just past 8 mm. So this is our starting reading.

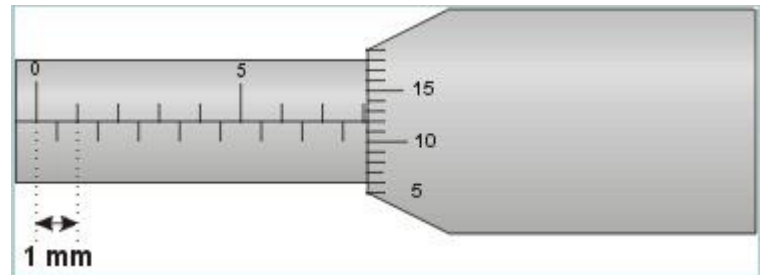

Now it is necessary to read the thimble on the micrometer. The thimble reading is made where the line from the barrel crosses the thimble. In this diagram, the thimble reads 12. However, this is NOT 12 mm but 0.12 mm. Now the readings are added together to get the final reading:

$$8 \text{ mm} + 0.12 \text{ mm} = 8.12 \text{ mm}$$

Notice on the bottom of the scale in the barrel that there are also divisions. These are half millimetre divisions. They come into play when the thimble is only partly turned between whole millimetre marks as shown in the second micrometer below:

While the top of the scale on the barrel is still showing 8 mm, there is a tick mark now showing on the bottom of the scale before the thimble. If this is the situation, you must add 0.5 mm to the top reading before reading the thimble. So this reading would be:

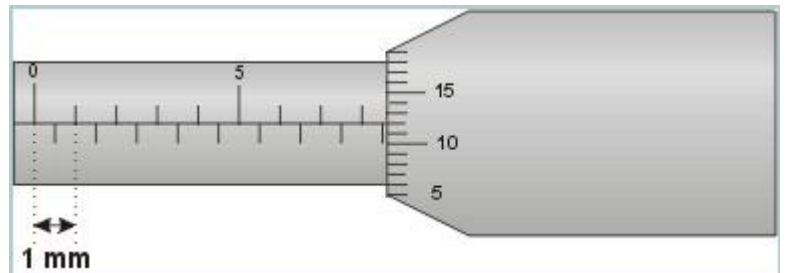

$$8 \text{ mm} + 0.5 \text{ mm} + 0.12 \text{ mm} = 8.62 \text{ mm}$$

While measuring with a vernier caliper, there might be some room for error depending on which lines match the best, with the micrometer, there is only one right answer. Therefore, micrometers are much more precise and accurate than vernier caliper are.

Other sites that will help you if you are having any trouble are the following:

<http://members.shaw.ca/ron.blond/Micrometer.APPLET/>

<http://www.upscale.utoronto.ca/PVB/Harrison/Micrometer/Micrometer.html>

ASSIGNMENT 10 – MICROMETERS

Write their measurements down beside each one.

1.

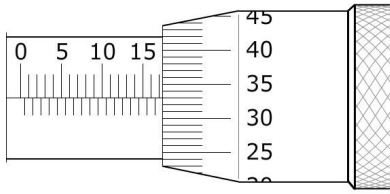

2.

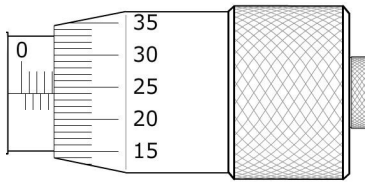

3.

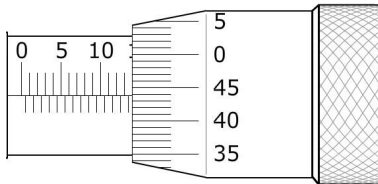

4.

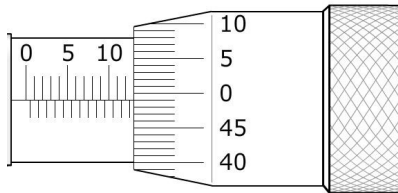

5.

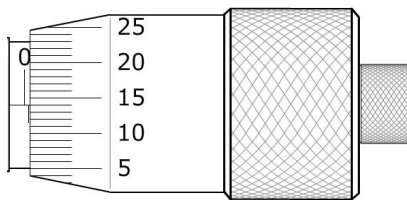

6.

